

PR151~PR157

FAST RECOVERY PLASTIC RECTIFIER

VOLTAGE 50 to 1000 Volt **CURRENT** 1.5 Ampere

DO-15 Unit:mm

FEATURES

- Low Leakage Current
- High current capability
- High reliability
- Lead free in compliance with EU RoHS

MECHANICAL DATA

- Case Material: Molded Plastic.
- UL Flammability Classification Rating 94V-0

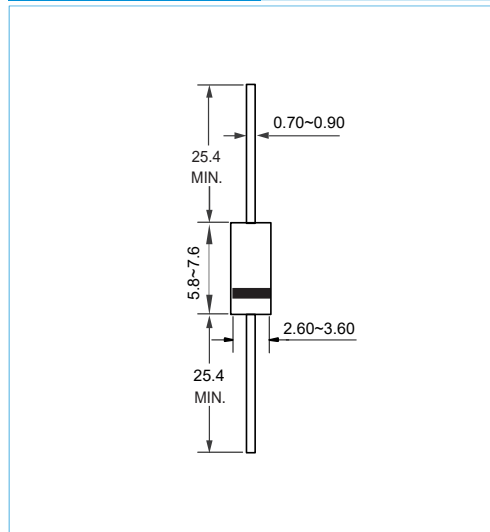

MAXIMUM RATINGS AND ELECTRICAL CHARACTERISTICS

Ratings at 25°C ambient temperature unless otherwise specified.

PARAMETER	SYMBOL	PR151	PR152	PR153	PR154	PR155	PR156	PR157	UNITS
Maximum Recurrent Peak Reverse Voltage	V_{RRM}	50	100	200	400	600	800	1000	V
Maximum RMS Voltage	V_{RMS}	35	70	140	280	420	560	7000	V
Maximum DC Blocking Voltage	V_{DC}	50	100	200	400	600	800	1000	V
Maximum Average Forward Current (see FIG.1)	$I_{F(AV)}$	1.5							A
Peak Forward Surge Current : 8.3ms single half sine-wave superimposed on rated load	I_{FSM}	50							A
Maximum Forward Voltage at 1.5 A	V_F	1.30							V
Maximum DC Reverse Current at Rated DC Blocking Voltage	I_R	5.0 100							μA
Maximum Reverse Recovery Time(Note 1)	t_{rr}	150				250	500		ns
Thermal Resistance	$R_{\theta JA}$	50							$^{\circ}C / W$
Typical Junction Capacitance (Note2)	C_J	30							pF
Operating Junction Temperature Range	T_J	-55 to +150							$^{\circ}C$
Storage Temperature Range	T_{STG}	-55 to +150							$^{\circ}C$

NOTES:

1. Reverse Recovery Test Conditions: $I_F=0.5A, I_R=1.0A, I_{rr}=0.25A$
2. Measured at 1.0MHz and applied reverse voltage of 4.0 volt

PR151~PR157

RATING AND CHARACTERISTIC CURVES

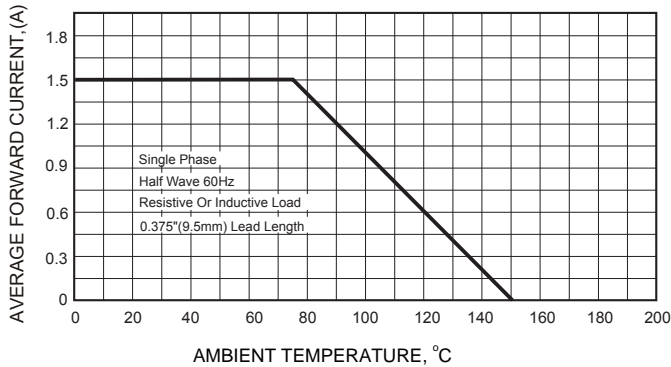

Fig. 1 Forward Current Derating Curve

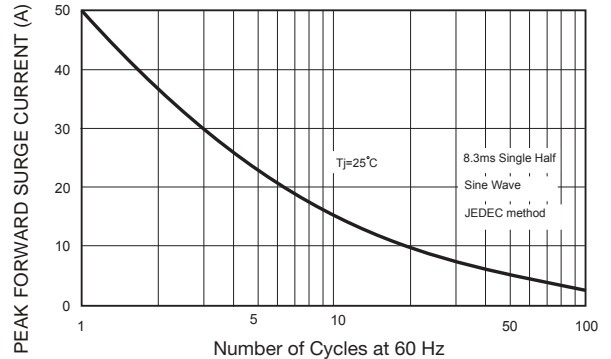

Fig. 2 Surge Current Derating Curve

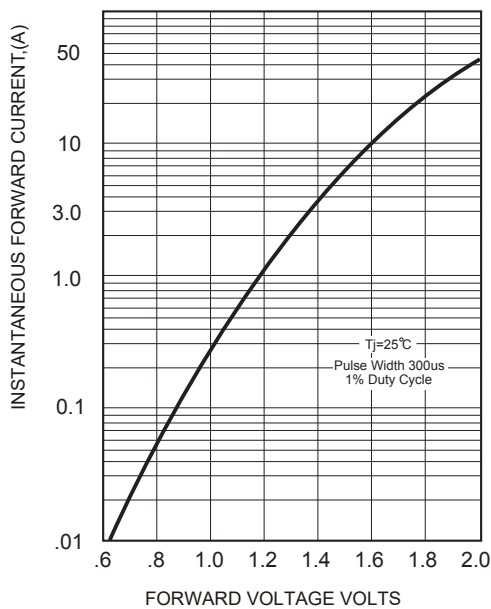

Fig. 3 Typical Forward Characteristics

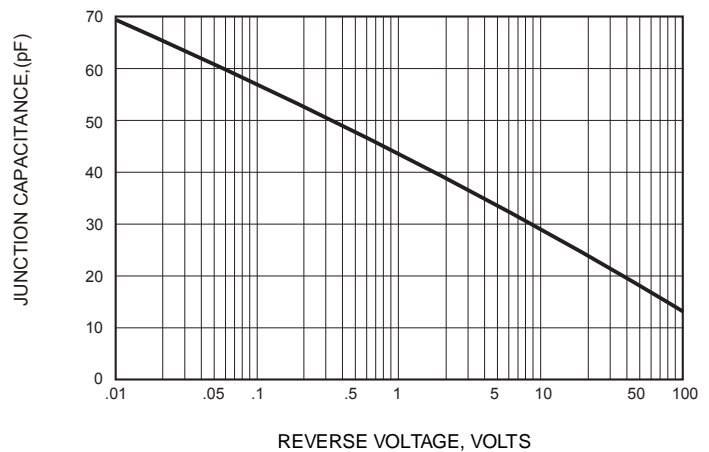
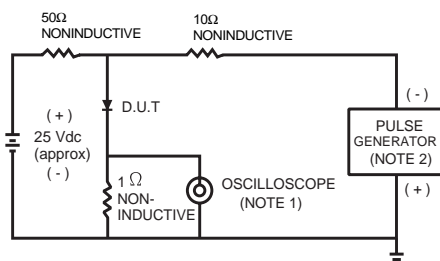

Fig. 4 Typical Junction Capacitance



NOTES:
3. Rise time = 7.0 ns max; Input impedance = 1.0 megaohm 22 pf.
4. Rise time = 10 ns max; Source impedance = 50 ohms.

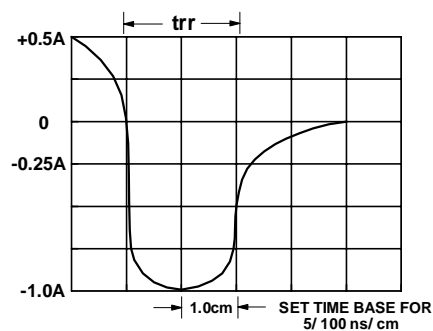

Fig. 5 Reverse Recovery Time Characteristic and Test Circuit

PR151~PR157

ORDER INFORMATION

- Packing information

Part Number	Case	Reel Size	QUANTITY
PR151~PR157	DO-15	13 Inch	4000