

FR501G~FR507G

FAST RECOVERY PLASTIC RECTIFIER

VOLTAGE 50 to 1000 Volt **CURRENT** 5.0 Ampere

DO-201AD

Unit:mm

FEATURES

- Low Forward Voltage Drop
- Glass Passivated Junction
- High Current Capability
- High Reliability
- High Surge Current Capability
- Lead free in compliance with EU RoHS

MECHANICAL DATA

- Case Material: Molded Plastic.
- UL Flammability Classification Rating 94V-0

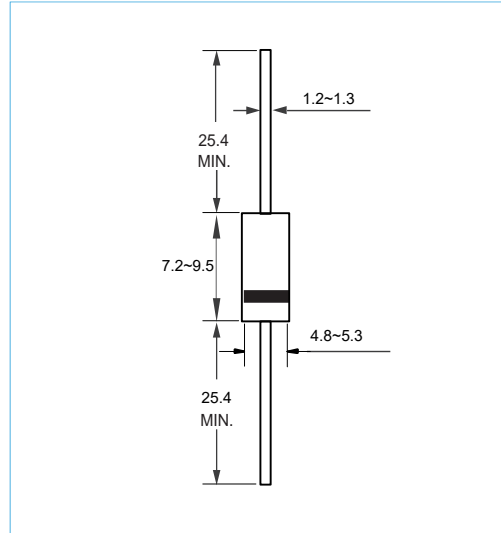

MAXIMUM RATINGS AND ELECTRICAL CHARACTERISTICS

Ratings at 25°C ambient temperature unless otherwise specified.

PARAMETER	SYMBOL	FR501G	FR502G	FR503G	FR504G	FR505G	FR506G	FR507G	UNITS
Maximum Recurrent Peak Reverse Voltage	V_{RRM}	50	100	200	400	600	800	1000	V
Maximum RMS Voltage	V_{RMS}	35	70	140	280	420	560	700	V
Maximum DC Blocking Voltage	V_{DC}	50	100	200	400	600	800	1000	V
Maximum Average Forward Current (see FIG.1)	$I_{F(AV)}$	5.0							A
Peak Forward Surge Current : 8.3ms single half sine-wave superimposed on rated load	I_{FSM}	200							A
Maximum Forward Voltage at 5.0 A	V_F	1.35							V
Maximum DC Reverse Current at Rated DC Blocking Voltage	I_R	10 150							μA
Maximum Reverse Recovery Time(Note 1)	t_{rr}	150				250	500		ns
Thermal Resistance	$R_{\theta JA}$	22							$^{\circ}C / W$
Typical Junction Capacitance (Note2)	C_J	28							pF
Operating Junction Temperature Range	T_J	-55 to +150							$^{\circ}C$
Storage Temperature Range	T_{STG}	-55 to +150							$^{\circ}C$

NOTES:

1. Reverse Recovery Test Conditions: $I_F=0.5A, I_R=1.0A, I_{rr}=0.25A$
2. Measured at 1.0MHz and applied reverse voltage of 4.0 volt

FR501G~FR507G

RATING AND CHARACTERISTIC CURVES

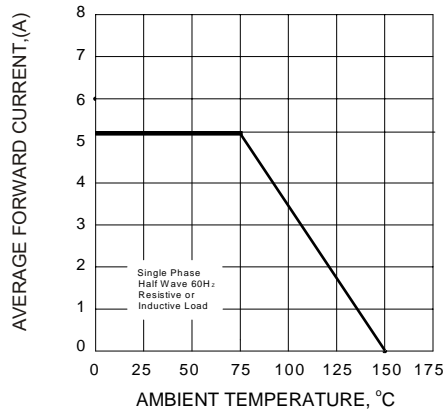

Fig. 1 Forward Current Derating Curve

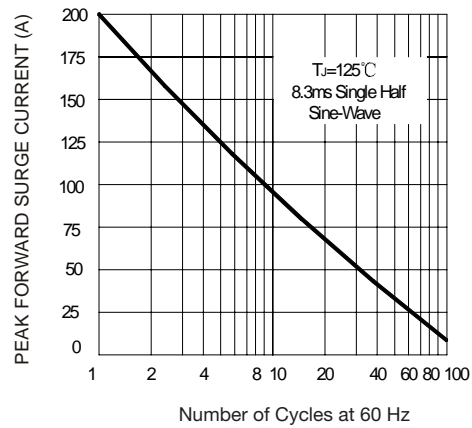

Fig. 2 Surge Current Derating Curve

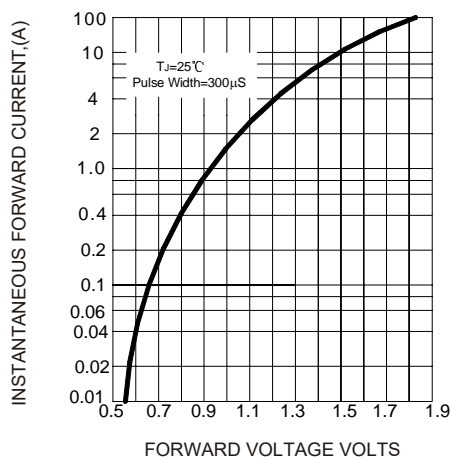

Fig. 3 Typical Forward Characteristics

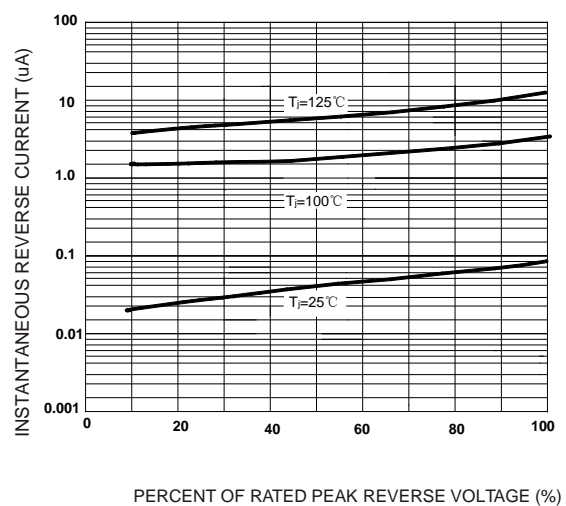

Fig. 4 Typical Reverse Characteristics

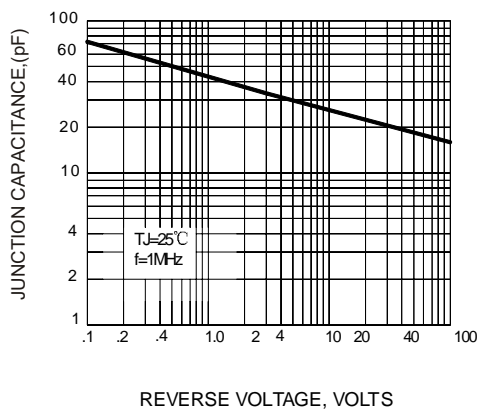
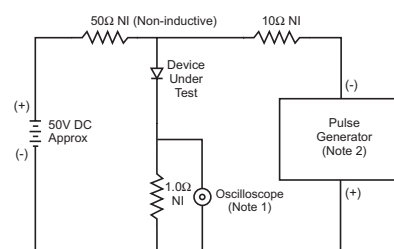

Fig. 5 Typical Junction Capacitance



Notes:
 1. Rise Time = 7.0ns max. Input Impedance = 1.0MΩ, 22pF.
 2. Rise Time = 10ns max. Input Impedance = 50Ω.

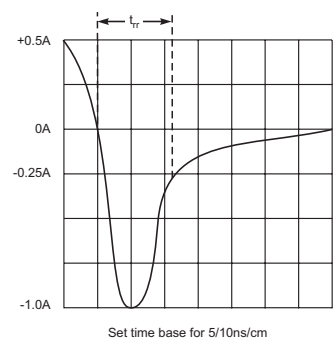

Fig. 6 Reverse Recovery Time Characteristic and Test Circuit

FR501G~FR507G

ORDER INFORMATION

- Packing information

Part Number	Case	Reel Size	QUANTITY
FR501G~FR5007G	DO-201AD	7 Inch	1200