

FR151~FR157

FAST RECOVERY PLASTIC RECTIFIER

VOLTAGE 50 to 1000 Volt **CURRENT** 1.5 Ampere

DO-15 Unit:mm

FEATURES

- Low Forward Voltage Drop
- High Current Capability
- High Reliability
- High Surge Current Capability
- Lead free in compliance with EU RoHS

MECHANICAL DATA

- Case Material: Molded Plastic.
- UL Flammability Classification Rating 94V-0

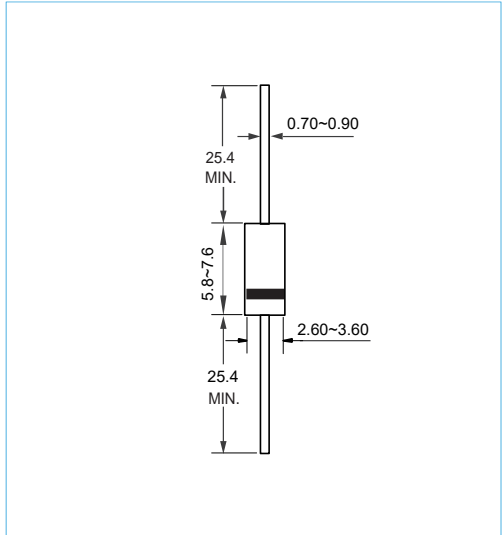

MAXIMUM RATINGS AND ELECTRICAL CHARACTERISTICS

Ratings at 25°C ambient temperature unless otherwise specified.

PARAMETER	SYMBOL	FR151	FR152	FR153	FR154	FR155	FR156	FR157	UNITS
Maximum Recurrent Peak Reverse Voltage	V_{RRM}	50	100	200	400	600	800	1000	V
Maximum RMS Voltage	V_{RMS}	35	70	140	280	420	560	700	V
Maximum DC Blocking Voltage	V_{DC}	50	100	200	400	600	800	1000	V
Maximum Average Forward Current (see FIG.1)	$I_{F(AV)}$	1.5							A
Peak Forward Surge Current : 8.3ms single half sine-wave superimposed on rated load	I_{FSM}	50							A
Maximum Forward Voltage at 1.5 A	V_F	1.3							V
Maximum DC Reverse Current at Rated DC Blocking Voltage	I_R	5.0 100							μA
Typical Junction Capacitance (Note1)	t_{rr}	150				250	500		ns
Reverse Recovery Time (Note 2)	C_J	30							pF
Thermal Resistance	$R_{\theta JA}$	35							$^{\circ}C / W$
Operating Junction Temperature Range	T_J	-55 to +150							$^{\circ}C$
Storage Temperature Range	T_{STG}	-55 to +150							$^{\circ}C$

NOTES:

1. Measured at 1.0MHz and applied reverse voltage of 4.0 volt
2. Measured with $I_F = 0.5A$, $I_R = 1.0A$, $IRR = 0.25A$.

FR151~FR157

RATING AND CHARACTERISTIC CURVES

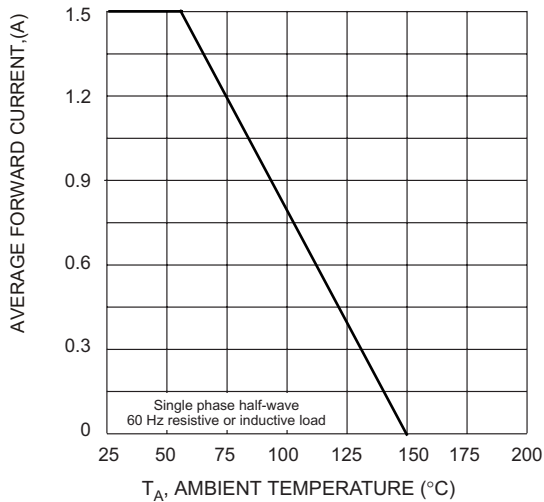

Fig. 1 Forward Derating Curve

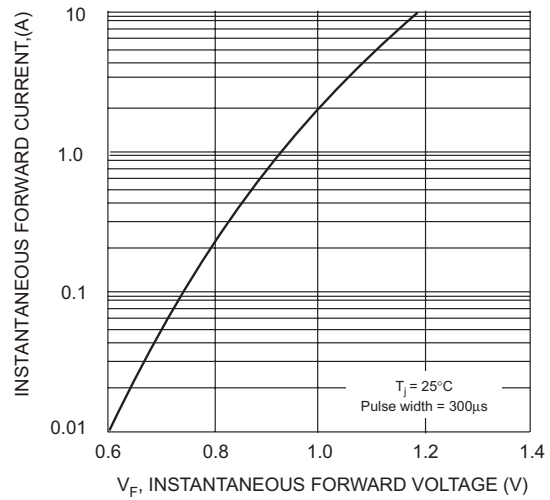

Fig. 2 Typical Forward Characteristics

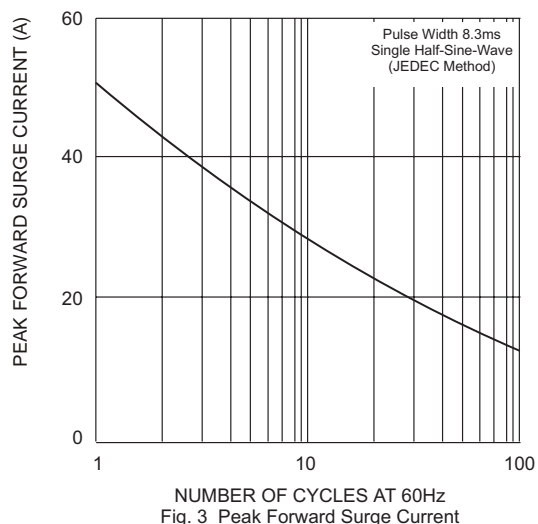

Fig. 3 Peak Forward Surge Current

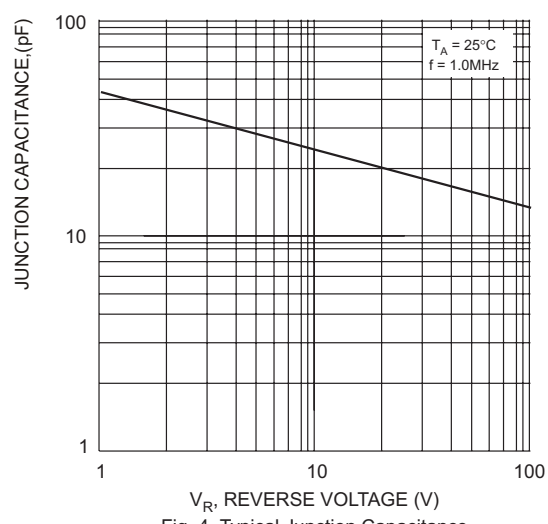
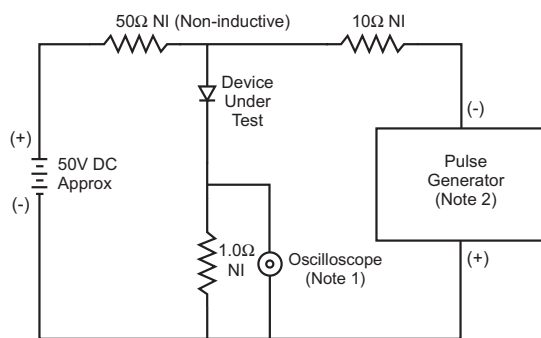
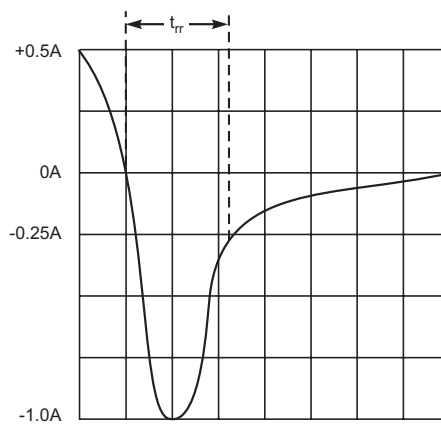

Fig. 4 Typical Junction Capacitance



- Notes:
1. Rise Time = 7.0ns max. Input Impedance = 1.0MΩ, 22pF.
 2. Rise Time = 10ns max. Input Impedance = 50Ω.



Set time base for 5/10ns/cm

Fig. 5 Reverse Recovery Time Characteristic and Test Circuit

FR151~FR157

ORDER INFORMATION

- Packing information

Part Number	Case	Reel Size	QUANTITY
FR151~FR157	DO-15	13 Inch	4000