

## 5.0SMLJ11A~5.0SMLJ400CA

### SURFACE MOUNT TRANSIENT VOLTAGE SUPPRESSOR POWER 5000 Watt

**BREAK DOWN VOLTAGE** 11 to 400 Volt

SMC / DO-214AB

Unit:mm

#### FEATURES

- Glass passivated junction
- Excellent clamping capability
- Low profile package
- Fast response time: typical less than 1ps from 0V to BV min
- Lead free in compliance with EU RoHS 2.0

#### MECHANICAL DATA

- Case: Molded plastic over passivated junction.
- Polarity: Color band denotes cathode end

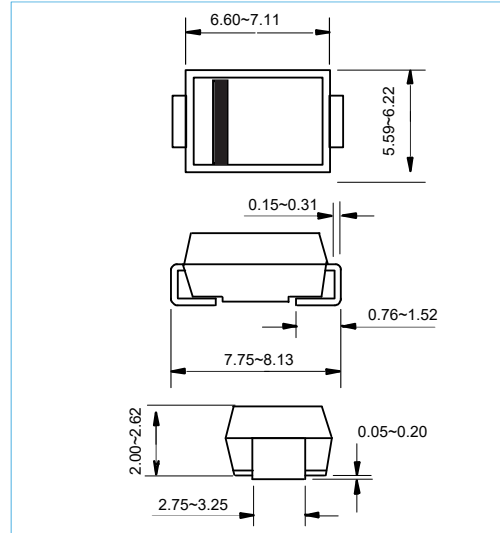

### MAXIMUM RATINGS AND ELECTRICAL CHARACTERISTICS

Ratings at 25°C ambient temperature unless otherwise specified.

Rating	Symbol	Value	Units
Peak Pulse Power Dissipation on 10/1000us waveform(Note2,3)	$P_{PP}$	5000	Watts
Steady State Power Dissipation	$P_{M(AV)}$	6.5	W
Peak Pulse Current on 10/1000us waveform(Note2)	$I_{PPM}$	See page 2,3	Amps
Typical Thermal Resistance Junction to Air (Notes 2)	$R_{\theta JA}$	23	°C / W
Operating Junction and Storage Temperature Range	$T_J, T_{STG}$	-55 to +175	°C

#### NOTES :

1. High Temperature Solder Exemptions Applied, see EU Directive Annex 7a.
2. Non-repetitive current pulse and derated above  $T_A=25^\circ\text{C}$
3. Mounted on 8.0mm<sup>2</sup> copper pads to each terminal.
4. 8.3ms, single half sine-wave or equivalent square wave, duty cycle=4 pulses per. Minutes maximum.

## 5.0SMLJ11A~5.0SMLJ400CA

### ELECTRICAL CHARACTERISTICS @25°C

PART NUMBER	REVERSE STAND-OFF VOLTAGE $V_{RWM}(V)$	BREAKDOWN VOLTAGE $V_{BR}(V)$ MIN.@IT	BREAKDOWN VOLTAGE $V_{BR}(V)$ MAX.@IT	TEST CURRENT $I_T$ (mA)	MAXIMUM CLAMPING VOLTAGE	PEAK PULSE CURRENT $I_{pp}$ (A)	REVERSE LEAKAGE	DEVICE MARKING CODE
					@ $I_{pp}$ $V_c(V)$		@ $V_{RWM}$ $I_D(\mu A)$	
5.0SMLJ 11A	11	12.2	13.5	10	18.2	275	800	5PEN
5.0SMLJ 12A	12	13.3	14.7	10	19.9	252	800	5PEP
5.0SMLJ 13A	13	14.4	15.9	10	21.5	233	500	5PEQ
5.0SMLJ 14A	14	15.6	17.2	10	23.2	216	200	5PER
5.0SMLJ 15A	15	16.7	18.5	1	24.4	205	100	5PES
5.0SMLJ 16A	16	17.8	19.7	1	26	193	50	5PET
5.0SMLJ 17A	17	18.9	20.9	1	27.6	181	20	5PEU
5.0SMLJ 18A	18	20	22.1	1	29.2	172	10	5PEV
5.0SMLJ 20A	20	22.2	24.5	1	32.4	155	5	5PEW
5.0SMLJ 22A	22	24.4	26.9	1	35.5	141	5	5PEX
5.0SMLJ 24A	24	26.7	29.5	1	38.9	129	5	5PEZ
5.0SMLJ 26A	26	28.9	31.9	1	42.1	119	5	5PFE
5.0SMLJ 28A	28	31.1	34.4	1	45.4	110	5	5PFG
5.0SMLJ 30A	30	33.3	36.8	1	48.4	103	5	5PFK
5.0SMLJ 33A	33	36.7	40.6	1	53.3	93.9	5	5PFM
5.0SMLJ 36A	36	40	44.2	1	58.1	86.1	5	5PFP
5.0SMLJ 40A	40	44.4	49.1	1	64.5	77.6	5	5PFR
5.0SMLJ 43A	43	47.8	52.8	1	69.4	72.1	5	5PFT
5.0SMLJ 45A	45	50	55.3	1	72.7	68.8	5	5PFV
5.0SMLJ 48A	48	53.3	58.9	1	77.4	64.7	5	5PFX
5.0SMLJ 51A	51	56.7	62.7	1	82.4	60.7	5	5PFZ
5.0SMLJ 54A	54	60	66.3	1	87.1	57.5	5	5RGE
5.0SMLJ 58A	58	64.4	71.2	1	93.6	53.5	5	5PGG
5.0SMLJ 60A	60	66.7	73.7	1	96.8	51.7	5	5PGK
5.0SMLJ 64A	64	71.1	78.6	1	103	48.6	5	5PGM
5.0SMLJ 70A	70	77.8	86	1	113	44.3	5	5PGP
5.0SMLJ 75A	75	83.3	92.1	1	121	41.4	5	5PGR
5.0SMLJ 78A	78	86.7	95.8	1	126	39.7	5	5PGT
5.0SMLJ 85A	85	94.4	104	1	137	36.5	5	5PGV
5.0SMLJ 90A	90	100	111	1	146	34.3	5	5PGX
5.0SMLJ 100A	100	111	123	1	162	30.9	5	5PGZ
5.0SMLJ 110A	110	122	135	1	177	28.3	5	5PHE
5.0SMLJ 120A	120	133	147	1	193	26	5	5PHG
5.0SMLJ 130A	130	144	159	1	209	24	5	5PHK
5.0SMLJ 150A	150	167	185	1	243	20.6	5	5PHM
5.0SMLJ 160A	160	178	197	1	259	19.3	5	5PHP
5.0SMLJ 170A	170	189	209	1	275	18.2	5	5PHR
5.0SMLJ 180A	180	200	220	1	292	17.1	5	5PHT
5.0SMLJ 190A	190	211	258	1	308	16.2	5	5PHV
5.0SMLJ 200A	200	224	247	1	324	15.4	5	5PHW
5.0SMLJ 220A	220	246	272	1	356	14.0	5	5PHX
5.0SMLJ 250A	250	279	309	1	405	12.3	5	5PHZ
5.0SMLJ 300A	300	335	371	1	486	10.3	5	5PJE
5.0SMLJ 350A	350	391	432	1	567	8.8	5	5PJG
5.0SMLJ 400A	400	447	494	1	648	7.7	5	5PJK

## 5.0SMLJ11A~5.0SMLJ400CA

### ELECTRICAL CHARACTERISTICS @25°C

PART NUMBER	REVERSE STAND- OFF VOLTAGE $V_{RWM}(V)$	BREAKDOWN VOLTAGE $V_{BR}(V)$ MIN.@IT	BREAKDOWN VOLTAGE $V_{BR}(V)$ MAX.@IT	TEST CURRENT $I_T$ (mA)	MAXIMUM CLAMPING VOLTAGE @Ipp	PEAK PULSE CURRENT Ipp (A)	REVERSE LEAKAGE @ $V_{RWM}$	DEVICE MARKING CODE
					$V_C(V)$		$I_D(\mu A)$	
5.0SMLJ 11CA	11	12.2	13.5	10	18.2	275	800	5BEN
5.0SMLJ 12CA	12	13.3	14.7	10	19.9	252	800	5BEP
5.0SMLJ 13CA	13	14.4	15.9	10	21.5	233	500	5BEQ
5.0SMLJ 14CA	14	15.6	17.2	10	23.2	216	200	5BER
5.0SMLJ 15CA	15	16.7	18.5	1	24.4	205	100	5BES
5.0SMLJ 16CA	16	17.8	19.7	1	26	193	50	5BET
5.0SMLJ 17CA	17	18.9	20.9	1	27.6	181	20	5BEU
5.0SMLJ 18CA	18	20	22.1	1	29.2	172	10	5BEV
5.0SMLJ 20CA	20	22.2	24.5	1	32.4	155	5	5BEW
5.0SMLJ 22CA	22	24.4	26.9	1	35.5	141	5	5BEX
5.0SMLJ 24CA	24	26.7	29.5	1	38.9	129	5	5BEZ
5.0SMLJ 26CA	26	28.9	31.9	1	42.1	119	5	5BFE
5.0SMLJ 28CA	28	31.1	34.4	1	45.4	110	5	5BFG
5.0SMLJ 30CA	30	33.3	36.8	1	48.4	103	5	5BFX
5.0SMLJ 33CA	33	36.7	40.6	1	53.3	93.9	5	5BFM
5.0SMLJ 36CA	36	40	44.2	1	58.1	86.1	5	5BFP
5.0SMLJ 40CA	40	44.4	49.1	1	64.5	77.6	5	5BFR
5.0SMLJ 43CA	43	47.8	52.8	1	69.4	72.1	5	5BFT
5.0SMLJ 45CA	45	50	55.3	1	72.7	68.8	5	5BFV
5.0SMLJ 48CA	48	53.3	58.9	1	77.4	64.7	5	5BFX
5.0SMLJ 51CA	51	56.7	62.7	1	82.4	60.7	5	5BFZ
5.0SMLJ 54CA	54	60	66.3	1	87.1	57.5	5	5BGE
5.0SMLJ 58CA	58	64.4	71.2	1	93.6	53.5	5	5BGG
5.0SMLJ 60CA	60	66.7	73.7	1	96.8	51.7	5	5BGK
5.0SMLJ 64CA	64	71.1	78.6	1	103	48.6	5	5BGM
5.0SMLJ 70CA	70	77.8	86	1	113	44.3	5	5BGP
5.0SMLJ 75CA	75	83.3	92.1	1	121	41.4	5	5BGR
5.0SMLJ 78CA	78	86.7	95.8	1	126	39.7	5	5BGT
5.0SMLJ 85CA	85	94.4	104	1	137	36.5	5	5BGV
5.0SMLJ 90CA	90	100	111	1	146	34.3	5	5BGX
5.0SMLJ 100CA	100	111	123	1	162	30.9	5	5BGZ
5.0SMLJ 110CA	110	122	135	1	177	28.3	5	5BHE
5.0SMLJ 120CA	120	133	147	1	193	26	5	5BHG
5.0SMLJ 130CA	130	144	159	1	209	24	5	5BHK
5.0SMLJ 150CA	150	167	185	1	243	20.6	5	5BHM
5.0SMLJ 160CA	160	178	197	1	259	19.3	5	5BHP
5.0SMLJ 170CA	170	189	209	1	275	18.2	5	5BHR

For Bidirectional type having  $V_{RWM}$  of 20 volts and less, the  $I_r$  limit is double.

# 5.0SMLJ11A~5.0SMLJ400CA

Ratings and Characteristic Curves ( $T_A=25^\circ\text{C}$  unless otherwise noted)

**Figure 1 - Peak Pulse Power Rating Curve**

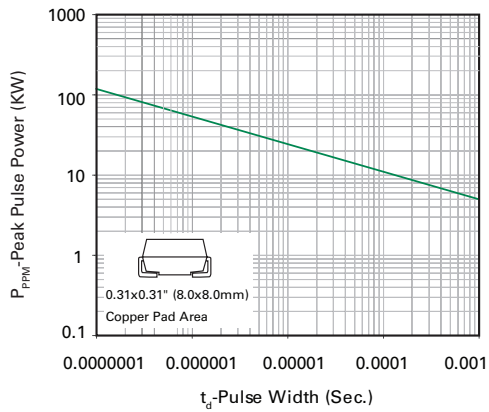

**Figure 2 - Peak Pulse Power or Current Derating Curve vs Initial Junction Temperature**

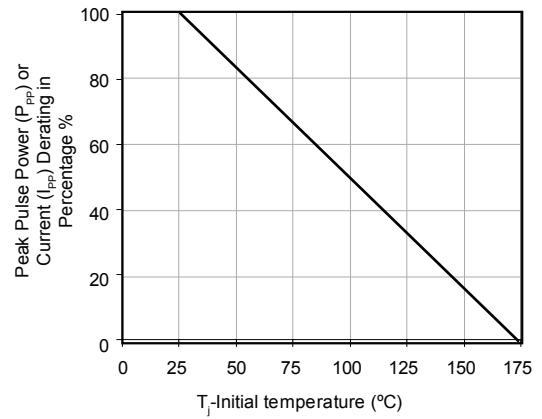

**Figure 3 - Pulse Waveform**

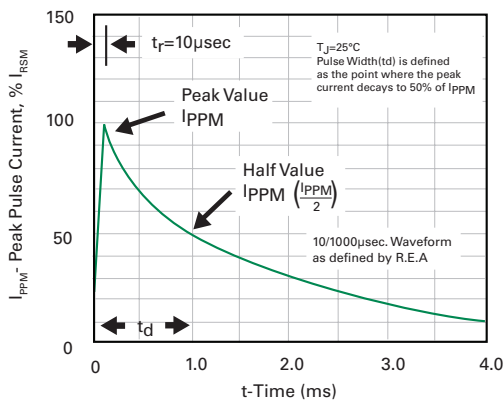

**Figure 4 - Typical Junction Capacitance**

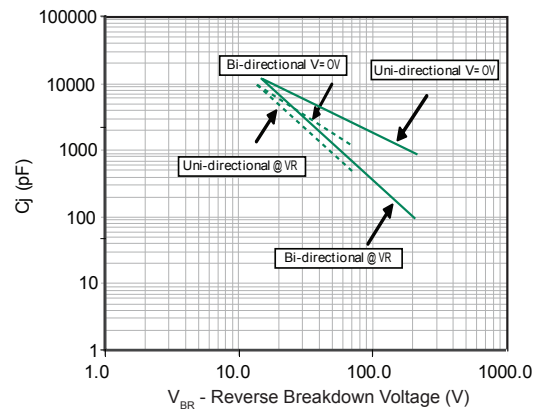

**Figure 5 - Steady State Power Derating Curve**

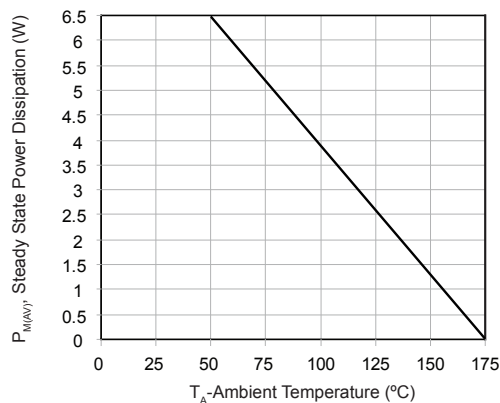

**Figure 6 - Maximum Non-Repetitive Peak Forward Surge Current Uni-Directional Only**

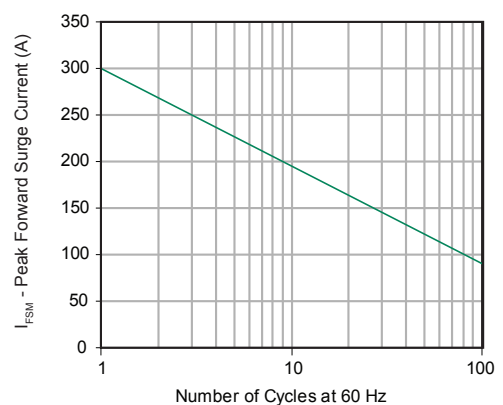

# 5.0SMLJ11A~5.0SMLJ400CA

## MOUNTING PAD LAYOUT

**SMC / DO-214AB**

Unit:Inch(mm)

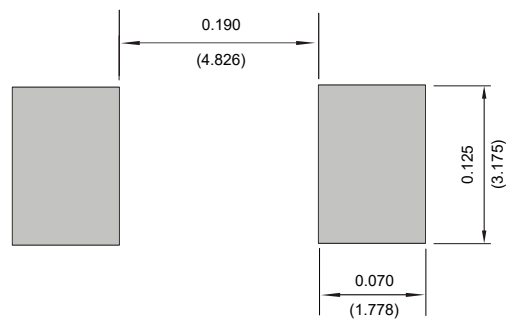

## ORDER INFORMATION

- Packing information

Part Number	Case	Reel Size	QUANTITY
5.0SMLJ11A~5.0SMLJ400CA	SMC	13 Inch	3000