

# ER1A~ER1J

## SURFACE MOUNT SUPERFAST RECTIFIER

**VOLTAGE** 50 to 600 Volt **CURRENT** 1 Ampere

**SMB / DO-214AA** Unit:mm

### FEATURES

- Superfast Recovery Times For High Efficiency
- Glass Passivated Junction
- Easy Pick And Place
- Moisture Sensitivity Level 1
- Lead free in compliance with EU RoHS 2.0

### MECHANICAL DATA

- Case Material: Molded Plastic.
- UL Flammability Classification Rating 94V-0

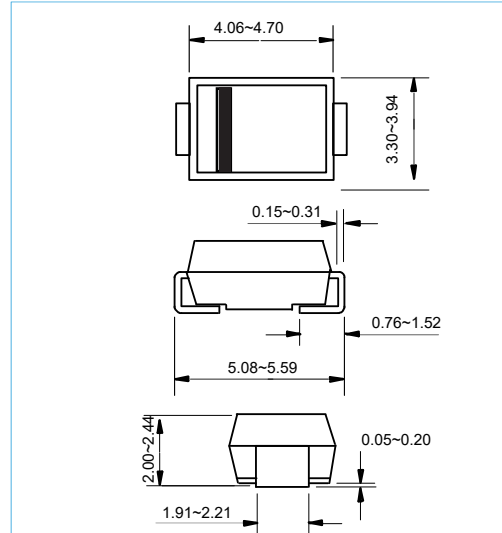
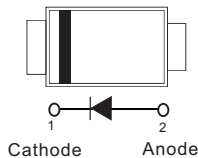

### MAXIMUM RATINGS AND ELECTRICAL CHARACTERISTICS

Ratings at 25°C ambient temperature unless otherwise specified.

PARAMETER	SYMBOL	ER1A	ER1B	ER1D	ER1G	ER1J	UNITS
Maximum Recurrent Peak Reverse Voltage	$V_{RRM}$	50	100	200	400	600	V
Maximum RMS Voltage	$V_{RMS}$	35	70	140	280	420	V
Maximum DC Blocking Voltage	$V_{DC}$	50	100	200	400	600	V
Maximum Average Forward Current (see FIG.1)	$I_{F(AV)}$	1					A
Peak Forward Surge Current : 8.3ms single half sine-wave superimposed on rated load	$I_{FSM}$	30					A
Maximum Forward Voltage at 1A	$V_F$	0.95		1.25		1.70	V
Maximum DC Reverse Current at Rated DC Blocking Voltage $T_J=25^{\circ}C$ $T_J=100^{\circ}C$	$I_R$	5.0 150					uA
Maximum Reverse Recovery Time(Note 1)	$t_{rr}$	35					ns
Thermal Resistance	$R_{\theta JL}$	34					$^{\circ}C / W$
Typical Junction Capacitance (Note2)	$C_J$	10					pF
Operating Junction Temperature Range	$T_J$	-55 to +150					$^{\circ}C$
Storage Temperature Range	$T_{STG}$	-55 to +150					$^{\circ}C$

#### NOTES:

1. Reverse Recovery Test Conditions:  $I_F=0.5A, I_R=1.0A, I_{rr}=0.25A$
2. Measured at 1.0MHz and applied reverse voltage of 4.0 volt

# ER1A~ER1J

## RATING AND CHARACTERISTIC CURVES

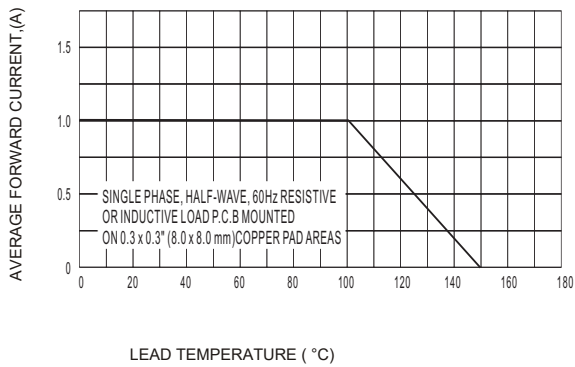

Fig. 1 Forward Current Derating Curve

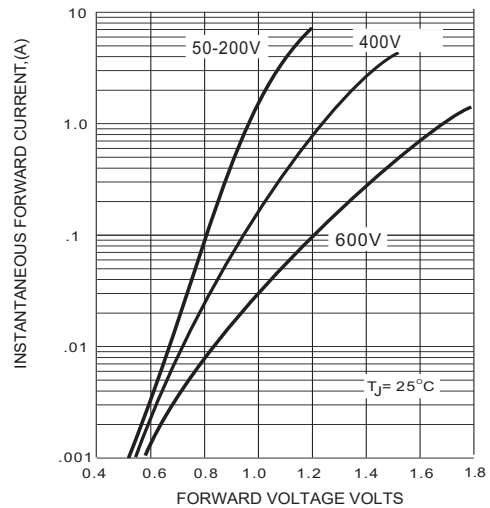

Fig. 2 Typical Forward Characteristics

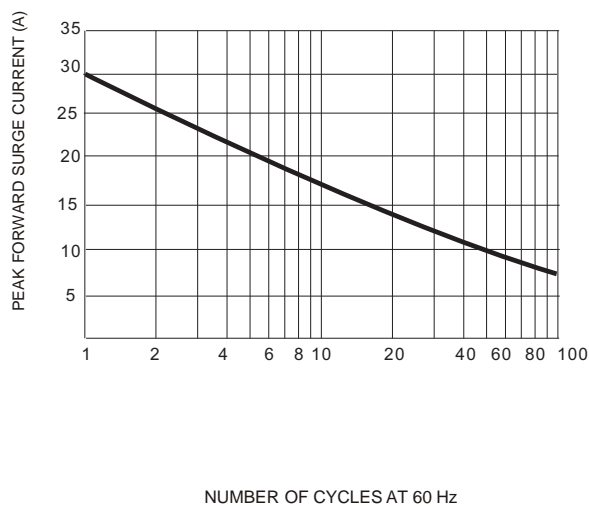

Fig. 3 Surge Current Derating Curve

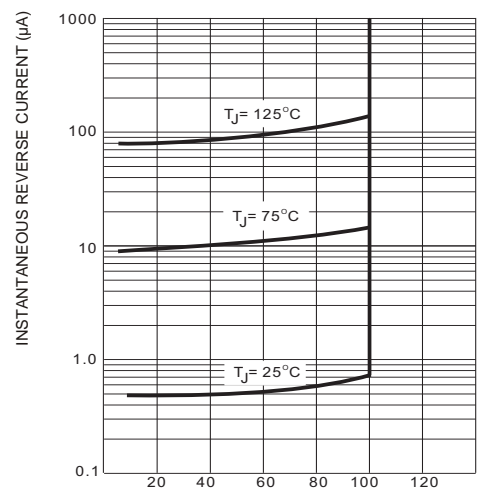

Fig. 4 Typical Reverse Characteristics

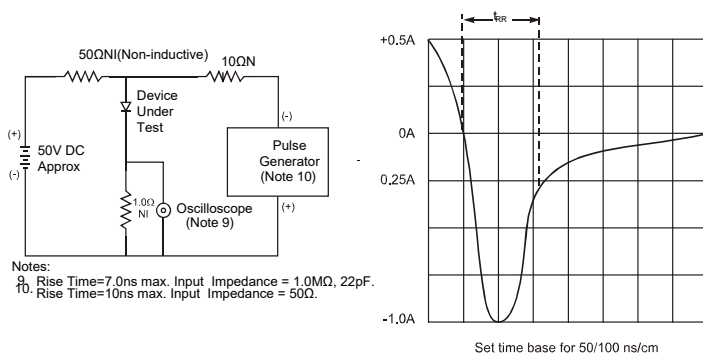

Fig. 5 Reverse Recovery Time Characteristic and Test Circuit

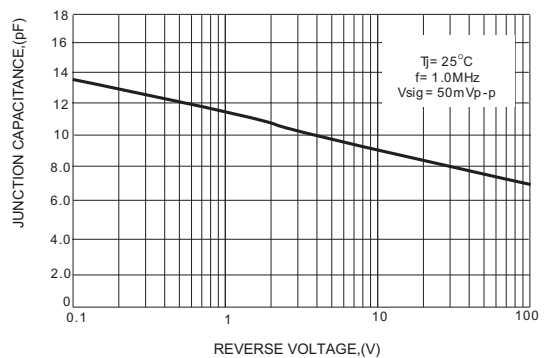

Fig. 6 Typical Junction Capacitance

# ER1A~ER1J

## MOUNTING PAD LAYOUT

### SMB / DO-214AA

Unit:Inch(mm)

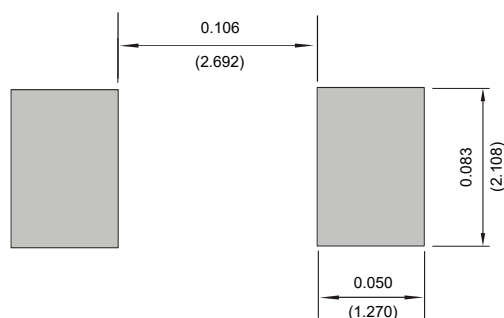

## ORDER INFORMATION

- Packing information

Part Number	Case	Reel Size	QUANTITY
ER1A~ER1J	SMB	13 Inch	3000