

1N957B~1N979B

AXIAL LEAD ZENER DIODES

VOLTAGE 6.8 to 56 Volts **POWER** 500 mWatts

DO-35 Unit : inch(mm)

FEATURES

- Planar Die construction
- 500mW Power Dissipation
- Ideally Suited for Automated Assembly Processes
- Lead free in compliance with EU RoHS 2011/65/EU directive

MECHANICAL DATA

- Case: Molded glass DO-35
- Terminals: Solderable per MIL-STD-750, Method 2026
- Ordering information: Suffix :"-35" to order DO-35 Package
- Packing information

B/P - 2K per Bulk box

T/R - 10K per 15" plastic Reel

T/B - 5K per horiz. tape & Ammo box

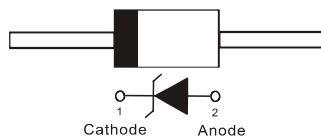
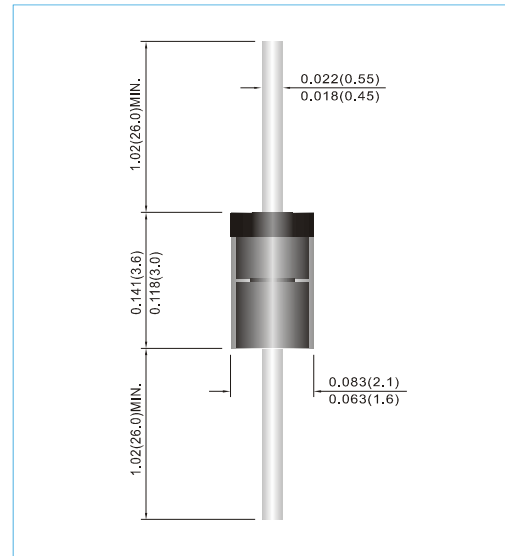

MAXIMUM RATINGS AND ELECTRICAL CHARACTERISTICS (TA=25°C unless otherwise noted)

Parameter	Symbol	Value	Units
Power Dissipation at Tamb = 25 °C	P _{TOT}	500	mW
Junction Temperature	T _J	175	°C
Storage Temperature Range	T _{STG}	-65 to +175	°C

Valid provided that leads at a distance of 8mm from case are kept at ambient temperature.

Parameter	Symbol	Min.	Typ.	Max.	Units
Thermal Resistance Junction to Ambient Air	R _{θJA}	--	--	0.3	°C/mW
Forward Voltage at I _F = 200mA	V _F	--	--	1.1	V

Valid provided that leads at a distance of 10 mm from case are kept at ambient temperature.

1N957B~1N979B

ELECTRICAL CHARACTERISTICS (T_J=25°C unless otherwise noted)

Part Number	V _Z (Volts) (Note 1)				Z _Z (Ω) (Note 2)			I _R @ V _R		I _{ZM} (mA) (Note 3)
	Min.	Typ.	Max.	@ I _{ZT} (mA)	Z _{ZT} @ I _{ZT}	Z _{ZK} @ I _{ZK}		μA	Volts	
						Ω	mA			
1N957B	6.46	6.8	7.14	18.5	4.5	700	1.0	150	5.2	47
1N958B	7.125	7.5	7.875	16.5	5.5	700	0.5	75	5.7	42
1N959B	7.79	8.2	8.61	15	6.5	700	0.5	50	6.2	38
1N960B	8.645	9.1	9.555	14	7.5	700	0.5	25	6.9	35
1N961B	9.50	10	10.50	12.5	8.5	700	0.25	10	7.6	32
1N962B	10.45	11	11.55	11.5	9.5	700	0.25	5	8.4	28
1N963B	11.40	12	12.60	10.5	11.5	700	0.25	5	9.1	26
1N964B	12.35	13	13.65	9.5	13	700	0.25	5	9.9	24
1N965B	14.25	15	15.75	8.5	16	700	0.25	5	11.4	21
1N966B	15.20	16	16.80	7.8	17	700	0.25	5	12.2	19
1N967B	17.10	18	18.90	7.0	21	750	0.25	5	13.7	17
1N968B	19.00	20	21.00	6.2	25	750	0.25	5	15.2	15
1N969B	20.90	22	23.10	5.6	29	750	0.25	5	16.7	14
1N970B	22.80	24	25.20	5.2	33	750	0.25	5	18.2	13
1N971B	25.65	27	28.35	4.6	41	750	0.25	5	20.6	11
1N972B	28.50	30	31.50	4.2	49	1000	0.25	5	22.8	10
1N973B	31.35	33	34.65	3.8	58	1000	0.25	5	25.1	9.2
1N974B	34.20	36	37.80	3.4	70	1000	0.25	5	27.4	8.5
1N975B	37.05	39	40.95	3.2	80	1000	0.25	5	29.7	7.8
1N976B	40.85	43	45.15	3.0	93	1500	0.25	5	32.7	7.0
1N977B	44.65	47	49.35	2.7	105	1500	0.25	5	35.8	6.4
1N978B	48.45	51	53.55	2.5	125	1500	0.25	5	38.8	5.9
1N979B	53.20	56	58.80	2.2	150	2000	0.25	5	42.6	5.4

Notes:

- Zener Voltage (V_Z) Measurement
Nominal zener voltage is measured with the device junction in the thermal equilibrium at the lead temperature (T_L) at 30°C ± 1°C and 3/8" lead length.
- Zener Impedance (Z_Z) Derivation
Z_{ZT} and Z_{ZK} are measured by dividing the ac voltage drop across the device by the ac current applied. The specified limits are for I_{Z(ac)} = 0.1 I_{Z(dc)} with the ac frequency = 60Hz.
- Maximum Zener Current Ratings (I_{ZM})
The maximum current handling capability on a worst case basis is limited by the actual zener voltage at the operation point and the power derating curve.

1N957B~1N979B

RATING AND CHARACTERISTIC CURVES

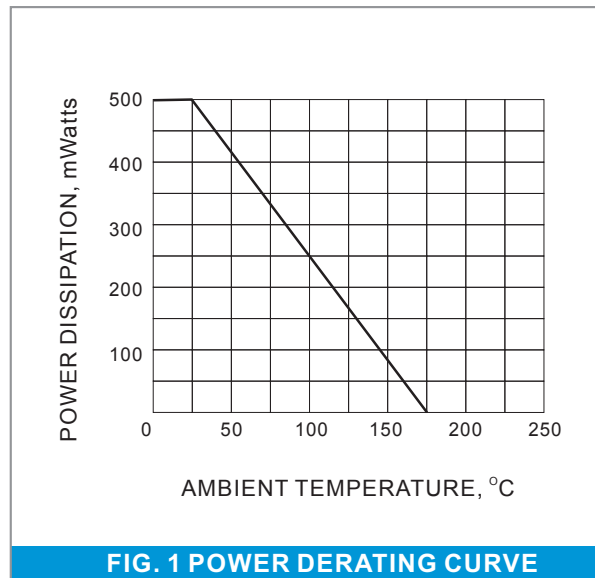

FIG. 1 POWER DERATING CURVE

1N957B~1N979B

Part No_packing code_Version

1N957B_AX_10001
 1N957B_AY_10001
 1N957B_R2_10001
 1N957B_BO_10001

For example :

RB500V-40_R2_00001



Packing Code XX				Version Code XXXXX		
Packing type	1 st Code	Packing size code	2 nd Code	HF or RoHS	1 st Code	2 nd ~5 th Code
Tape and Ammunition Box (T/B)	A	N/A	0	HF	0	serial number
Tape and Reel (T/R)	R	7"	1	RoHS	1	serial number
Bulk Packing (B/P)	B	13"	2			
Tube Packing (T/P)	T	26mm	X			
Tape and Reel (Right Oriented) (TRR)	S	52mm	Y			
Tape and Reel (Left Oriented) (TRL)	L	PANASERT T/B CATHODE UP (PBCU)	U			
FORMING	F	PANASERT T/B CATHODE DOWN (PBCD)	D			

1N957B~1N979B

Disclaimer

- Reproducing and modifying information of the document is prohibited without permission from Siyang Grande Electronics Co., Ltd..
- Siyang Grande Electronics Co., Ltd. reserves the rights to make changes of the content herein the document anytime without notification. Please refer to our website for the latest document.
- Siyang Grande Electronics Co., Ltd. disclaims any and all liability arising out of the application or use of any product including damages incidentally and consequentially occurred.
- Siyang Grande Electronics Co., Ltd. does not assume any and all implied warranties, including warranties of fitness for particular purpose, non-infringement and merchantability.
- Applications shown on the herein document are examples of standard use and operation. Customers are responsible in comprehending the suitable use in particular applications. Siyang Grande Electronics Co., Ltd. makes no representation or warranty that such applications will be suitable for the specified use without further testing or modification.
- The products shown herein are not designed and authorized for equipments requiring high level of reliability or relating to human life and for any applications concerning life-saving or life-sustaining, such as medical instruments, transportation equipment, aerospace machinery et cetera. Customers using or selling these products for use in such applications do so at their own risk and agree to fully indemnify Siyang Grande Electronics Co., Ltd. for any damages resulting from such improper use or sale.
- Since Grande uses lot number as the tracking base, please provide the lot number for tracking when complaining.