

1N5921B-G~1N5942B-G

SILICON ZENER DIODES

VOLTAGE 6.8 to 51 Volt **POWER** 1.5 Watt

DO-41G Unit: inch(mm)

FEATURES

- Low inductance
- High temperature soldering : 260°C /10 seconds at terminals
- Glass package has Underwriters Laboratory Flammability Classification
- Lead free in compliance with EU RoHS 2011/65/EU directive

MECHANICAL DATA

- Case: Molded Glass DO-41G
- Terminals: Axial leads, solderable per MIL-STD-750, Method 2026

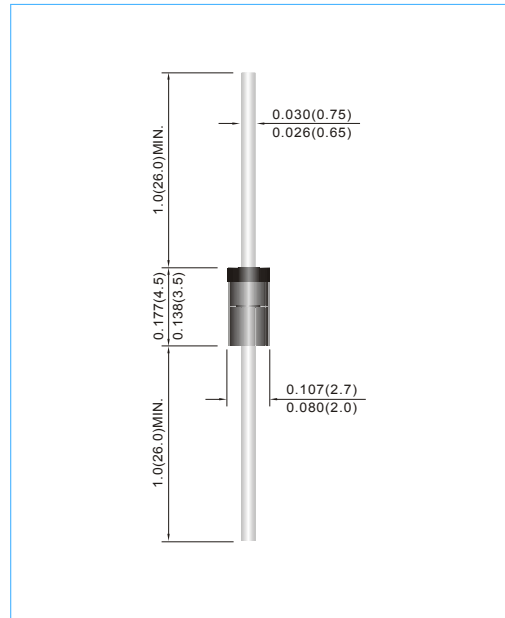
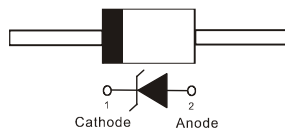

MAXIMUM RATINGS AND ELECTRICAL CHARACTERISTICS

Ratings at 25°C ambient temperature unless otherwise specified.

Parameter	Symbol	Value	Units
Power Dissipation at TA= 25 °C	P _{TOT}	1.5	W
Junction Temperature	T _J	-65 to +200	°C
Storage Temperature Range	T _{STG}	-65 to +200	°C

*Valid provided that leads at a distance of 10mm from case are kept at ambient temperature.

Parameter	Symbol	Min.	Typ.	Max.	Units
Thermal Resistance Junction to Ambient Air	R _{θJA}	--	--	170*	°C/W
Forward Voltage at I _F = 200mA	V _F	--	--	1.2	V

*Valid provided that leads at a distance of 10mm from case are kept at ambient temperature.

1N5921B-G~1N5942B-G

Part Number	Nominal Zener Voltage			Maximum Zener Impedance				Maximum Leakage Current	
	V _Z @ I _{ZT}			Z _{VT} @ I _{ZT}		Z _{VK} @ I _{ZK}		I _R	V _R
	Nom. V	Min. V	Max. V	Ω	mA	Ω	mA	μA	V
1N5921B-G	6.8	6.46	7.14	3	55.1	200	1	5	5.2
1N5922B-G	7.5	7.13	7.88	3	50	400	0.5	5	6
1N5923B-G	8.2	7.79	8.61	4	45.7	400	0.5	5	6.5
1N5924B-G	9.1	8.65	9.56	4	41.2	500	0.5	5	7
1N5925B-G	10	9.5	10.5	5	37.5	500	0.25	5	8
1N5926B-G	11	10.45	11.55	6	34.1	550	0.25	1	8.4
1N5927B-G	12	11.4	12.6	7	31.2	550	0.25	1	9.1
1N5928B-G	13	12.35	13.65	7	28.8	550	0.25	1	9.9
1N5929B-G	15	14.25	15.75	9	25	600	0.25	1	11.4
1N5930B-G	16	15.2	16.8	10	23.4	600	0.25	1	12.2
1N5931B-G	18	17.1	18.9	12	20.8	650	0.25	1	13.7
1N5932B-G	20	19	21	14	18.7	650	0.25	1	15.2
1N5933B-G	22	20.9	23.1	18	17	650	0.25	1	16.7
1N5934B-G	24	22.8	25.2	19	15.6	700	0.25	1	18.2
1N5935B-G	27	25.65	28.35	23	13.9	700	0.25	1	20.6
1N5936B-G	30	28.5	31.5	26	12.5	750	0.25	1	22.8
1N5937B-G	33	31.35	34.65	33	11.4	800	0.25	1	25.1
1N5938B-G	36	34.2	37.8	38	10.4	850	0.25	1	27.4
1N5939B-G	39	37.05	40.95	45	9.6	900	0.25	1	29.7
1N5940B-G	43	40.85	45.15	53	8.7	950	0.25	1	32.7
1N5941B-G	47	44.65	49.35	67	8	1000	0.25	1	35.8
1N5942B-G	51	48.45	53.55	70	7.3	1100	0.25	1	38.8

1N5921B-G~1N5942B-G

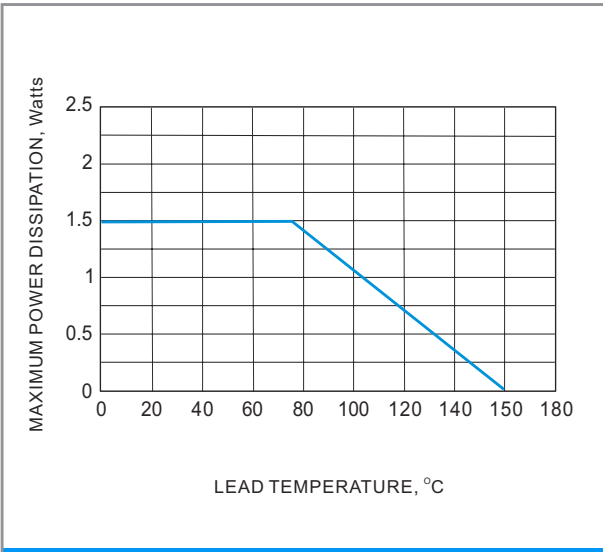

Fig.1 Steady State Power Derating

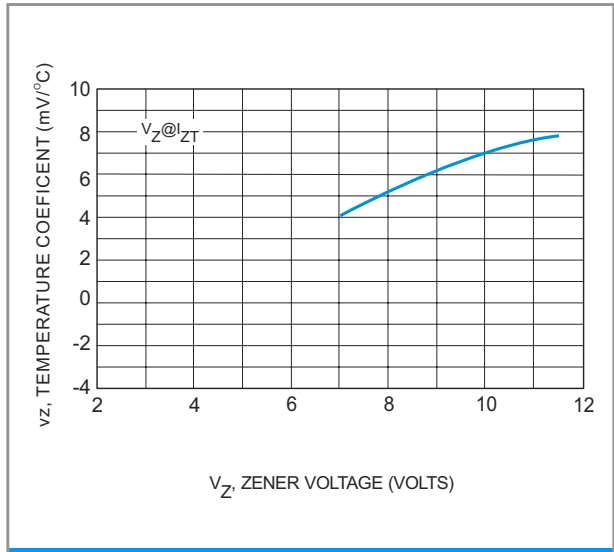

Fig.2 Temperature coefficient v.s. zener voltage, Vz(V)

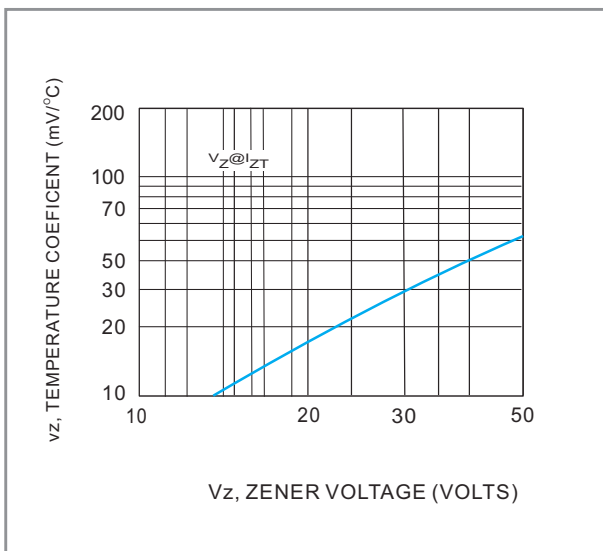

Fig.3 Temperature coefficient v.s. zener voltage, Vz(V)

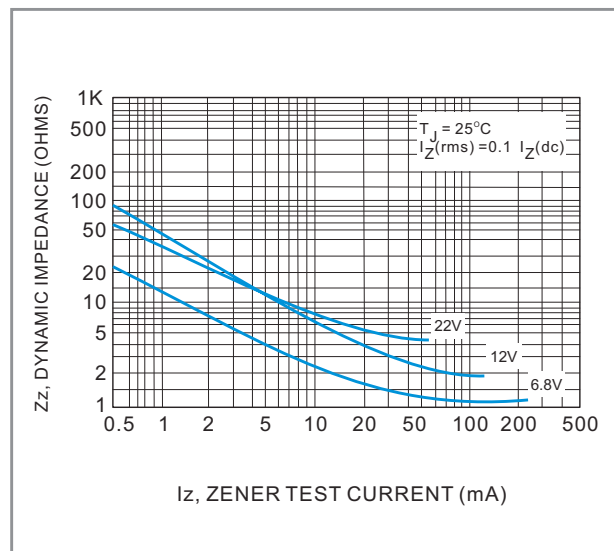

Fig.4 Zener impedance v.s. zener current

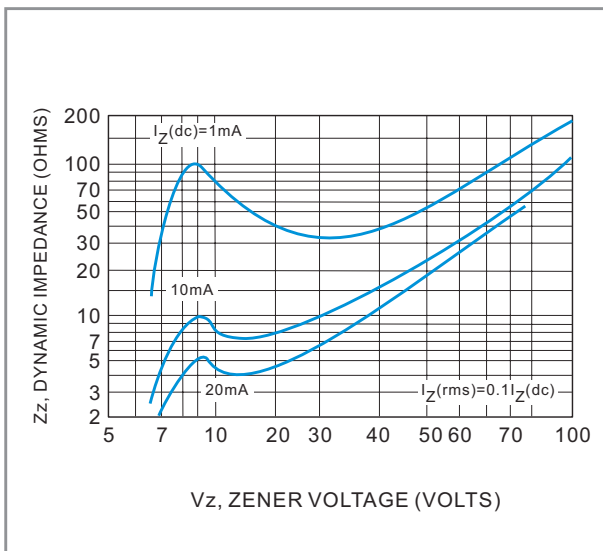

Fig.5 Zener impedance v.s. zener voltage

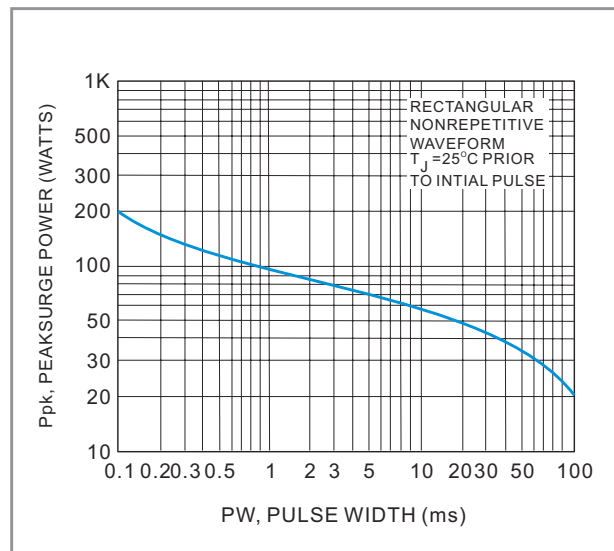
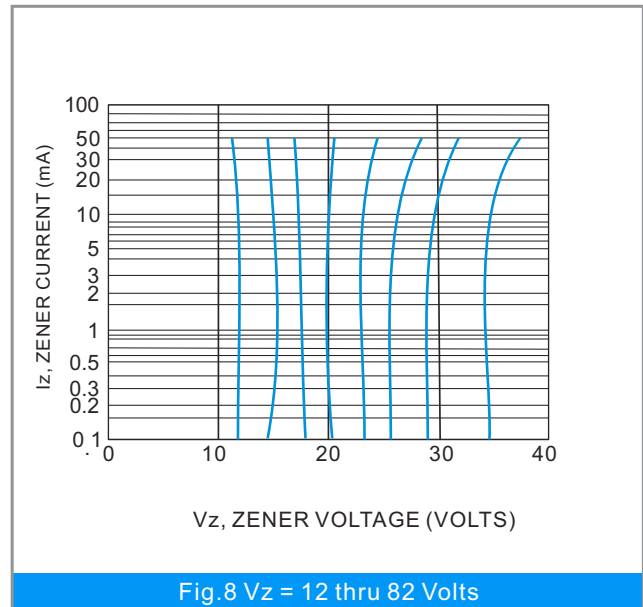
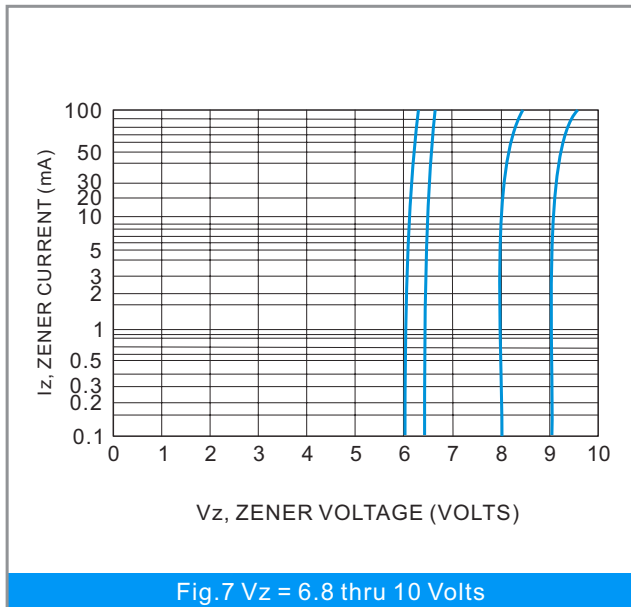

Fig.6 Maximum Surge Power

1N5921B-G~1N5942B-G



NOTE 3. ZENER VOLTAGE (V_z) MEASUREMENT

Nominal zener voltage is measured with the device function in thermal equilibrium with ambient temperature at 25°C

NOTE 4. ZENER IMPEDANCE (Z_z) DERIVATION

Z_{zt} and Z_{zk} are measured by dividing the ac voltage drop across the device by the ac current applied. The specified limits are for $I_z(ac) = 0.1 I_z(dc)$ with the ac frequency = 60Hz

1N5921B-G~1N5942B-G

Part No_packing code_Version

1N5921B-G_AY_10001

1N5921B-G_AX_10001

1N5921B-G_B0_10001

1N5921B-G_R2_10001

For example :

RB500V-40_R2_00001

Part No.

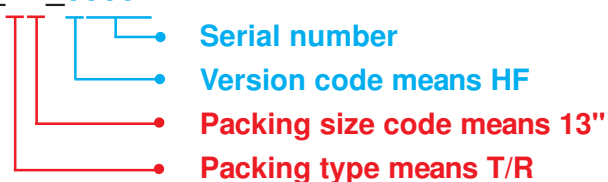

Packing Code XX				Version Code XXXXX		
Packing type	1 st Code	Packing size code	2 nd Code	HF or RoHS	1 st Code	2 nd ~5 th Code
Tape and Ammunition Box (T/B)	A	N/A	0	HF	0	serial number
Tape and Reel (T/R)	R	7"	1	RoHS	1	serial number
Bulk Packing (B/P)	B	13"	2			
Tube Packing (T/P)	T	26mm	X			
Tape and Reel (Right Oriented) (TRR)	S	52mm	Y			
Tape and Reel (Left Oriented) (TRL)	L	PANASERT T/B CATHODE UP (PBCU)	U			
FORMING	F	PANASERT T/B CATHODE DOWN (PBCD)	D			

1N5921B-G~1N5942B-G

Disclaimer

- Reproducing and modifying information of the document is prohibited without permission from Siyang Grande Electronics Co., Ltd..
- Siyang Grande Electronics Co., Ltd. reserves the rights to make changes of the content herein the document anytime without notification. Please refer to our website for the latest document.
- Siyang Grande Electronics Co., Ltd. disclaims any and all liability arising out of the application or use of any product including damages incidentally and consequentially occurred.
- Siyang Grande Electronics Co., Ltd. does not assume any and all implied warranties, including warranties of fitness for particular purpose, non-infringement and merchantability.
- Applications shown on the herein document are examples of standard use and operation. Customers are responsible in comprehending the suitable use in particular applications. Siyang Grande Electronics Co., Ltd. makes no representation or warranty that such applications will be suitable for the specified use without further testing or modification.
- The products shown herein are not designed and authorized for equipments requiring high level of reliability or relating to human life and for any applications concerning life-saving or life-sustaining, such as medical instruments, transportation equipment, aerospace machinery et cetera. Customers using or selling these products for use in such applications do so at their own risk and agree to fully indemnify Siyang Grande Electronics Co., Ltd. for any damages resulting from such improper use or sale.
- Since Grande uses lot number as the tracking base, please provide the lot number for tracking when complaining.