

GMZJ2.0~GMZJ56

SURFACE MOUNT ZENER DIODES

VOLTAGE 2.0 to 56 Volts **POWER** 500 mWatts

MICRO-MELF Unit : inch(mm)

FEATURES

- Planar Die construction
- 500mW Power Dissipation
- Ideally Suited for Automated Assembly Processes
- Lead free in comply with EU RoHS 2002/95/EC directives

MECHANICAL DATA

- Case: Molded Glass MICRO-MELF
- Terminals: Solderable per MIL-STD-750, Method 2026
- Mounting Position: Any
- Polarity : Color band denotes cathode end

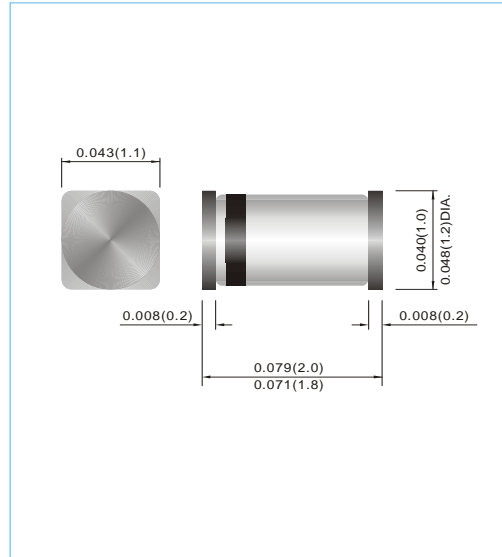
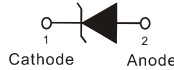
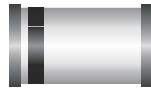

MAXIMUM RATINGS AND ELECTRICAL CHARACTERISTICS (T_A=25°C unless otherwise noted)

Parameter	Symbol	Value	Units
Power Dissipation at T _A = 25°C	P _{TOT}	500	mW
Operating Junction Temperature Range	T _J	175	°C
Storage Temperature Range	T _{STG}	-65 to + 175	°C

Valid provided that leads at a distance of 10mm from case are kept at ambient temperature.

Parameter	Symbol	Min.	Typ.	Max.	Units
Thermal Resistance Junction to Ambient Air	R _{θJA}	--	--	0.3	°C/mW
Forward Voltage at I _F = 100mA	V _F	--	--	1	V

Valid provided that leads at a distance of 10mm from case are kept at ambient temperature.

GMZJ2.0~GMZJ56

Part Number	Nominal Zener Voltage			Max. Zener Impedance				Max Reverse Leakage Current	
	V _Z @ I _{ZT}			Z _{ZT} @ I _{ZT}		Z _{ZK} @ I _{ZK}		I _R @ V _R	
	Nom. V	Min. V	Max. V	Ω	mA	Ω	mA	μA	V
500 mW Zener Diodes									
GMZJ 2.0A	2	1.88	2.1	100	5	1000	0.5	120	0.5
GMZJ 2.0B	2	2.02	2.2	100	5	1000	0.5	120	0.5
GMZJ 2.2A	2.2	2.12	2.3	100	5	1000	0.5	120	0.7
GMZJ 2.2B	2.2	2.22	2.41	100	5	1000	0.5	120	0.7
GMZJ 2.4A	2.4	2.33	2.52	100	5	1000	0.5	120	1
GMZJ 2.4B	2.4	2.43	2.63	100	5	1000	0.5	120	1
GMZJ 2.7A	2.7	2.54	2.75	110	5	1000	0.5	120	1
GMZJ 2.7B	2.7	2.69	2.91	110	5	1000	0.5	120	1
GMZJ 3.0A	3	2.85	3.07	120	5	1000	0.5	50	1
GMZJ 3.0B	3	3.01	3.22	120	5	1000	0.5	50	1
GMZJ 3.3A	3.3	3.16	3.38	120	5	1000	0.5	20	1
GMZJ 3.3B	3.3	3.32	3.53	120	5	1000	0.5	20	1
GMZJ 3.6A	3.6	3.46	3.69	100	5	1000	1	10	1
GMZJ 3.6B	3.6	3.6	3.84	100	5	1000	1	10	1
GMZJ 3.9A	3.9	3.74	4.01	100	5	1000	1	5	1
GMZJ 3.9B	3.9	3.89	4.16	100	5	1000	1	5	1
GMZJ 4.3A	4.3	4.04	4.29	100	5	1000	1	5	1
GMZJ 4.3B	4.3	4.17	4.43	100	5	1000	1	5	1
GMZJ 4.3C	4.3	4.3	4.57	100	5	1000	1	5	1
GMZJ 4.7A	4.7	4.44	4.68	90	5	900	1	5	1
GMZJ 4.7B	4.7	4.55	4.80	90	5	900	1	5	1
GMZJ 4.7C	4.7	4.68	4.93	90	5	900	1	5	1
GMZJ 5.1A	5.1	4.81	5.07	80	5	800	1	5	1.5
GMZJ 5.1B	5.1	4.94	5.2	80	5	800	1	5	1.5
GMZJ 5.1C	5.1	5.09	5.37	80	5	800	1	5	1.5
GMZJ 5.6A	5.6	5.28	5.55	60	5	500	1	5	2.5
GMZJ 5.6B	5.6	5.45	5.73	60	5	500	1	5	2.5
GMZJ 5.6C	5.6	5.61	5.91	60	5	500	1	5	2.5
GMZJ 6.2A	6.2	5.78	6.09	60	5	300	1	5	3
GMZJ 6.2B	6.2	5.96	6.27	60	5	300	1	5	3
GMZJ 6.2C	6.2	6.12	6.44	60	5	300	1	5	3
GMZJ 6.8A	6.8	6.29	6.63	20	5	150	0.5	2	3.5
GMZJ 6.8B	6.8	6.49	6.83	20	5	150	0.5	2	3.5
GMZJ 6.8C	6.8	6.66	7.01	20	5	150	0.5	2	3.5
GMZJ 7.5A	7.5	6.85	7.22	20	5	120	0.5	0.5	4
GMZJ 7.5B	7.5	7.07	7.45	20	5	120	0.5	0.5	4
GMZJ 7.5C	7.5	7.29	7.67	20	5	120	0.5	0.5	4
GMZJ 8.2A	8.2	7.53	7.92	20	5	120	0.5	0.5	5
GMZJ 8.2B	8.2	7.78	8.19	20	5	120	0.5	0.5	5
GMZJ 8.2C	8.2	8.03	8.45	20	5	120	0.5	0.5	5
GMZJ 9.1A	9.1	8.29	8.73	25	5	120	0.5	0.5	6
GMZJ 9.1B	9.1	8.57	9.01	25	5	120	0.5	0.5	6
GMZJ 9.1C	9.1	8.83	9.3	25	5	120	0.5	0.5	6
GMZJ 10A	10	9.12	9.59	30	5	120	0.5	0.2	7
GMZJ 10B	10	9.41	9.9	30	5	120	0.5	0.2	7
GMZJ 10C	10	9.7	10.2	30	5	120	0.5	0.2	7
GMZJ 10D	10	9.94	10.44	30	5	120	0.5	0.2	7
GMZJ 11A	11	10.18	10.71	30	5	120	0.5	0.2	8
GMZJ 11B	11	10.5	11.05	30	5	120	0.5	0.2	8
GMZJ 11C	11	10.82	11.38	30	5	120	0.5	0.2	8

GMZJ2.0~GMZJ56

Part Number	Nominal Zener Voltage			Max. Zener Impedance				Max Reverse Leakage Current	
	Vz @ IzT			ZzT @ IzT		Zzk @ Izk		Ir @ Vr	
	Nom. V	Min. V	Max. V	Ω	mA	Ω	mA	μA	V
500 mW Zener Diodes									
GMZJ 12A	12	11.13	11.71	30	5	110	0.5	0.2	9
GMZJ 12B	12	11.44	12.03	30	5	110	0.5	0.2	9
GMZJ 12C	12	11.74	12.35	30	5	110	0.5	0.2	9
GMZJ 13A	13	12.11	12.75	35	5	110	0.5	0.2	10
GMZJ 13B	13	12.55	13.21	35	5	110	0.5	0.2	10
GMZJ 13C	13	12.99	13.66	35	5	110	0.5	0.2	10
GMZJ 15A	15	13.44	14.13	40	5	110	0.5	0.2	11
GMZJ 15B	15	13.89	14.62	40	5	110	0.5	0.2	11
GMZJ 15C	15	14.35	15.09	40	5	110	0.5	0.2	11
GMZJ 16A	16	14.8	15.57	40	5	150	0.5	0.2	12
GMZJ 16B	16	15.25	16.04	40	5	150	0.5	0.2	12
GMZJ 16C	16	15.69	16.51	40	5	150	0.5	0.2	12
GMZJ 18A	18	16.22	17.06	45	5	150	0.5	0.2	13
GMZJ 18B	18	16.82	17.7	45	5	150	0.5	0.2	13
GMZJ 18C	18	17.42	18.33	45	5	150	0.5	0.2	13
GMZJ 20A	20	18.02	18.96	55	5	200	0.5	0.2	15
GMZJ 20B	20	18.63	19.59	55	5	200	0.5	0.2	15
GMZJ 20C	20	19.23	20.22	55	5	200	0.5	0.2	15
GMZJ 20D	20	19.72	20.72	55	5	200	0.5	0.2	15
GMZJ 22A	22	20.15	21.2	30	5	200	0.5	0.2	17
GMZJ 22B	22	20.64	21.71	30	5	200	0.5	0.2	17
GMZJ 22C	22	21.08	22.17	30	5	200	0.5	0.2	17
GMZJ 22D	22	21.52	22.63	30	5	200	0.5	0.2	17
GMZJ 24A	24	22.05	23.18	35	5	200	0.5	0.2	19
GMZJ 24B	24	22.61	23.77	35	5	200	0.5	0.2	19
GMZJ 24C	24	23.12	24.31	35	5	200	0.5	0.2	19
GMZJ 24D	24	23.63	24.85	35	5	200	0.5	0.2	19
GMZJ 27A	27	24.26	25.52	45	5	250	0.5	0.2	21
GMZJ 27B	27	24.97	26.26	45	5	250	0.5	0.2	21
GMZJ 27C	27	25.63	26.95	45	5	250	0.5	0.2	21
GMZJ 27D	27	26.29	27.64	45	5	250	0.5	0.2	21
GMZJ 30A	30	26.99	28.39	55	5	250	0.5	0.2	23
GMZJ 30B	30	27.7	29.13	55	5	250	0.5	0.2	23
GMZJ 30C	30	28.36	29.82	55	5	250	0.5	0.2	23
GMZJ 30D	30	29.02	30.51	55	5	250	0.5	0.2	23
GMZJ 33A	33	29.68	31.22	65	5	250	0.5	0.2	25
GMZJ 33B	33	30.32	31.88	65	5	250	0.5	0.2	25
GMZJ 33C	33	30.9	32.5	65	5	250	0.5	0.2	25
GMZJ 33D	33	31.49	33.11	65	5	250	0.5	0.2	25
GMZJ 36A	36	32.14	33.79	75	5	250	0.5	0.2	27
GMZJ 36B	36	32.79	34.49	75	5	250	0.5	0.2	27
GMZJ 36C	36	33.4	35.13	75	5	250	0.5	0.2	27
GMZJ 36D	36	34.01	35.77	75	5	250	0.5	0.2	27
GMZJ 39A	39	34.68	36.47	85	5	250	0.5	0.2	30
GMZJ 39B	39	35.36	37.19	85	5	250	0.5	0.2	30
GMZJ 39C	39	36	37.85	85	5	250	0.5	0.2	30
GMZJ 39D	39	36.63	38.52	85	5	250	0.5	0.2	30
GMZJ 43	43	40	45	90	5	-	-	0.2	33
GMZJ 47	47	44	49	90	5	-	-	0.2	36
GMZJ 51	51	48	54	110	5	-	-	0.2	39
GMZJ 56	56	53	60	110	5	-	-	0.2	43

GMZJ2.0~GMZJ56

Typical Characteristics ($T_{amb} = 25\text{ }^{\circ}\text{C}$ unless otherwise specified)

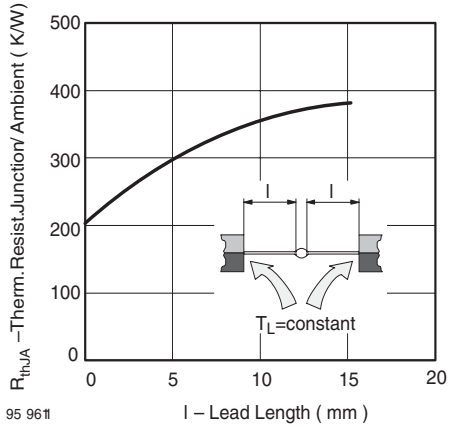

Fig. 1 Thermal Resistance vs. Lead Length

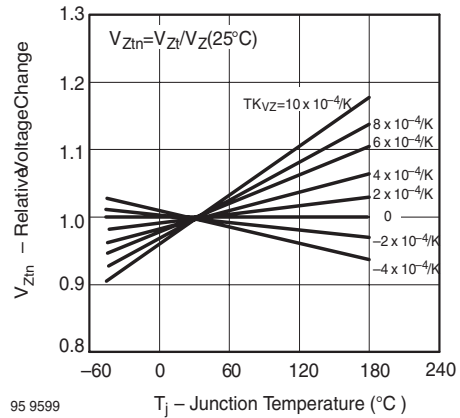

Fig. 4 Typical Change of Working Voltage vs. Junction Temperature

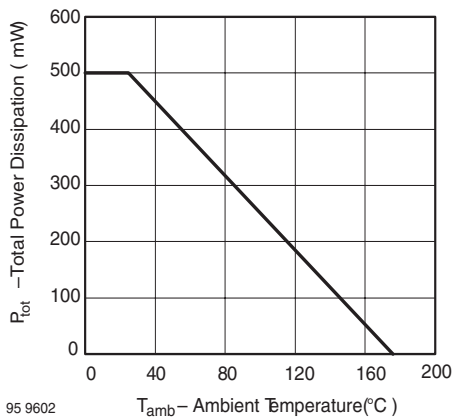

Fig. 2 Total Power Dissipation vs. Ambient Temperature

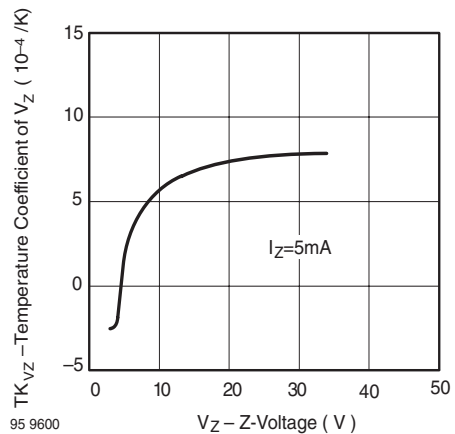

Fig. 5 Temperature Coefficient of V_Z vs. Z-Voltage

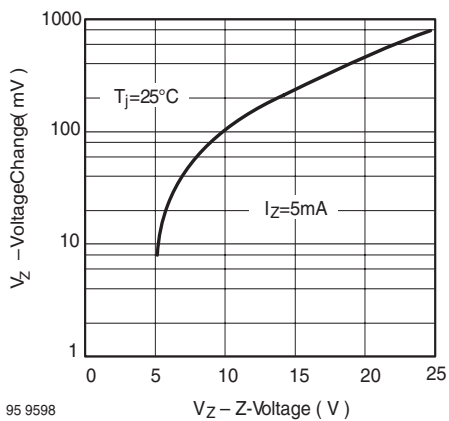

Fig. 3 Typical Change of Working Voltage under Operating Conditions at $T_{amb}=25\text{ }^{\circ}\text{C}$

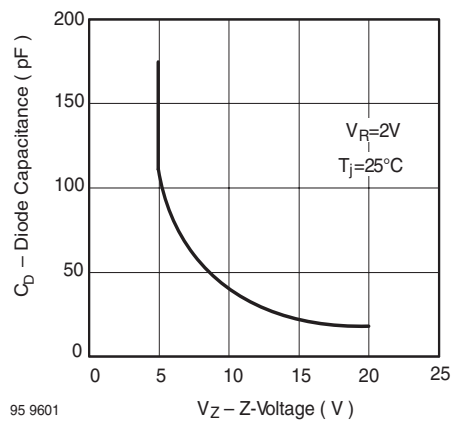

Fig. 6 Diode Capacitance vs. Z-Voltage

GMZJ2.0~GMZJ56

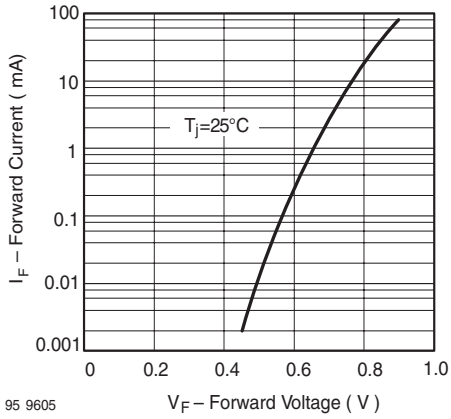

Fig. 7 Forward Current vs. Forward Voltage

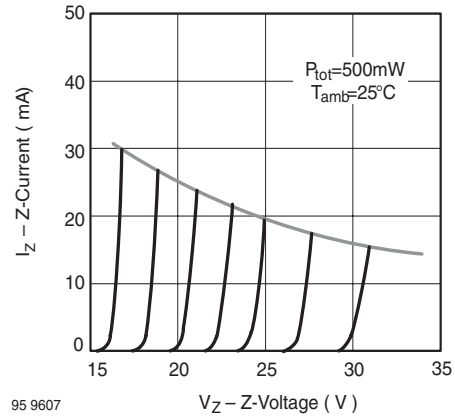

Fig. 9 Z-Current vs. Z-Voltage

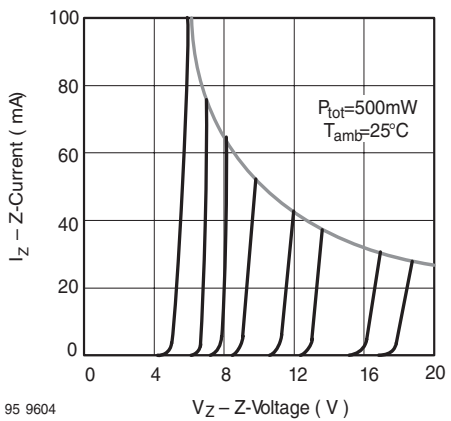

Fig. 8 Z-Current vs. Z-Voltage

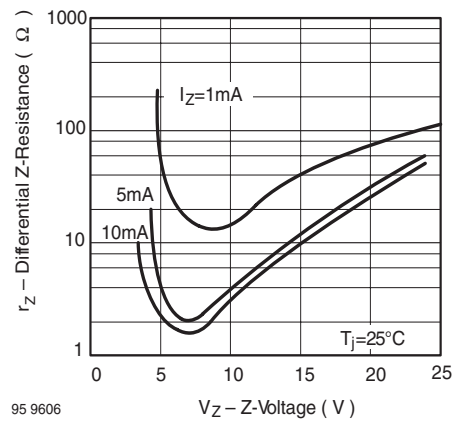

Fig. 10 Differential Z-Resistance vs. Z-Voltage

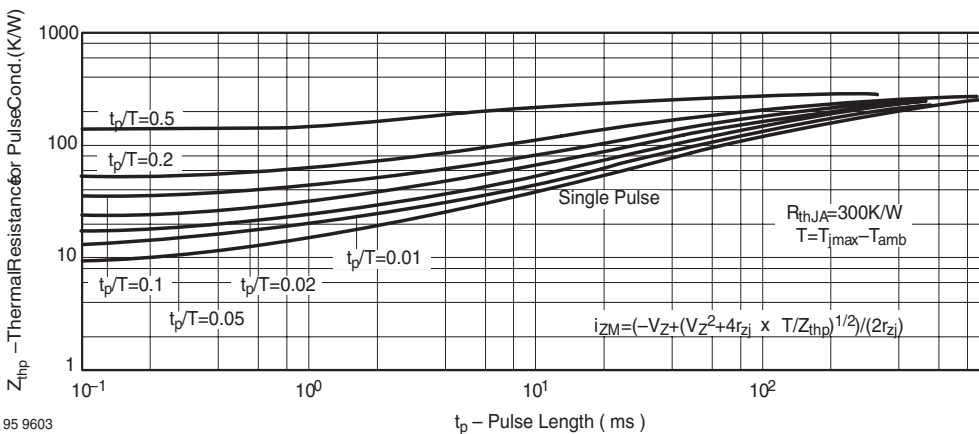

Fig. 11 Thermal Response

GMZJ2.0~GMZJ56

MOUNTING PAD LAYOUT

MICRO-MELF

Unit: inch (mm)

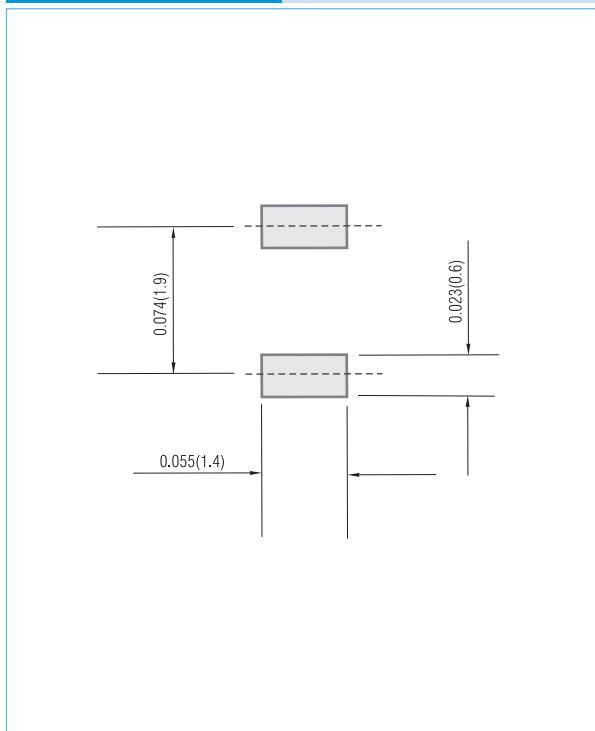

ORDER INFORMATION

- Packing information

T/R - 10K per 13" plastic Reel

T/R - 3K per 7" plastic Reel

GMZJ2.0~GMZJ56

Part No_packing code_Version

GMZJ2.0A_R1_10001

GMZJ2.0A_R2_10001

For example :

RB500V-40_R2_00001



Packing Code XX				Version Code XXXXX		
Packing type	1 st Code	Packing size code	2 nd Code	HF or RoHS	1 st Code	2 nd ~5 th Code
T/B	A	N/A	0	HF	0	serial number
T/R	R	7"	1	RoHS	1	serial number
B/P	B	13"	2			
T/P	T	26mm	X			
TRR	S	52mm	Y			
TRL	L	PBCU	U			
FORMING	F	PBCD	D			

GMZJ2.0~GMZJ56

Disclaimer

- Reproducing and modifying information of the document is prohibited without permission from Siyang Grande Electronics Co., Ltd..
- Siyang Grande Electronics Co., Ltd. reserves the rights to make changes of the content herein the document anytime without notification. Please refer to our website for the latest document.
- Siyang Grande Electronics Co., Ltd. disclaims any and all liability arising out of the application or use of any product including damages incidentally and consequentially occurred.
- Siyang Grande Electronics Co., Ltd. does not assume any and all implied warranties, including warranties of fitness for particular purpose, non-infringement and merchantability.
- Applications shown on the herein document are examples of standard use and operation. Customers are responsible in comprehending the suitable use in particular applications. Siyang Grande Electronics Co., Ltd. makes no representation or warranty that such applications will be suitable for the specified use without further testing or modification.
- The products shown herein are not designed and authorized for equipments requiring high level of reliability or relating to human life and for any applications concerning life-saving or life-sustaining, such as medical instruments, transportation equipment, aerospace machinery et cetera. Customers using or selling these products for use in such applications do so at their own risk and agree to fully indemnify Siyang Grande Electronics Co., Ltd. for any damages resulting from such improper use or sale.
- Since Grande uses lot number as the tracking base, please provide the lot number for tracking when complaining.